

# SERVICE MANUAL

# DOLPHIN SHOW V 1.0



ISSUE DATE : Feb.17, 2011



- ▶ Please read the manual carefully and keep it in mind before using this machine.
- ▶ Put this manual within touch of your reference in anytime.

# PRECAUTIONS FOR USE

The following safety precautions are given throughout this manual. They must be strictly followed to protect those who install, use or maintain this product as well as to protect players, visitors and property.

For safety reasons.

- The following suggestions should be adhered to:



## WARNING

Disregarding could result in serious injury.



## CAUTION

Disregarding could result in injury or product damage.

- The following graphic suggestions describe the types of precautions to be followed.



Indicates a care should be taken.



Forbidden.



Indicates a matter which must be performed.

- Precautions to be followed:

**Certain procedures require a qualified in-shop maintenance person or industry specialist. For such instructions, a qualified person must take care of the jobs.**

- Otherwise an electric shock, machine trouble, or a serious accident may result.
- Replacing the machine parts, inspecting and maintaining the machines, and troubleshooting must be assigned only to a qualified in-shop maintenance person or industry specialist. This booklet gives instructions that hazardous jobs in particular must be handled by an industry specialist. Qualified in-shop maintenance person and industry specialist are defined as follows.

### **Qualified in-shop maintenance person**

- A service staff shall have experience in operations of game machines. The staff shall be responsible for assembly, installation, inspection and maintenance of the machine.

### **Industry specialist**

- An industry specialist must be engaged in designing, manufacturing, inspecting and servicing amusement machines. He or she must have an education in electrical, electronic and mechanical engineering, and routinely maintain and repair amusement machines.

# PRECAUTIONS FOR USE

## WARNING

**Be sure to consult an industry specialist when setting up, moving or transporting this product.**

- This product should not be set up, moved or transported by any one other than an industry specialist.
- When installing this product, set the 4 leg levelers evenly on the floor and make sure that the product is installed stably in a horizontal position. Unstable installation may result in injury or accident.
- When installing this product, do not apply undue force on movable parts. Otherwise, injury and accident may result, or the product may be damaged.

**The machine for indoor usage only does not install outside.**



**Do not set the game machine up near emergency exits.**



**Protect the game machine from:**

- Rain or moisture.
- Direct sunlight.
- Direct heat from air-conditioning and heating equipment, etc..
- Hazardous flammable substances.
- Otherwise an accident or malfunction may result.



**Do not place containers holding chemicals or water on or near the game machine.**



**Do not place objects near the ventilating holes.**



**Do not bend the power cord by force or place heavy objects on it.**



**Never plug or unplug the power cord with wet hands.**



**Never unplug the game machine by pulling the power cord.**



## CAUTION

**Be sure to use indoor wiring within the specified voltage requirements. For extension cord, use the specified rating or more.**

**Be sure to use the attached power cord.**

**Never plug more than one cord at a time into the electrical receptacle.**



**Do not lay the power cord where people walk through.**



**Be sure to ground this product.**



**Do not exert excessive force when moving the machine.**



**For proper ventilation, keep the game machine 100mm(4") away from the walls.**

**Do not alter the system related dipswitch settings.**

# PRECAUTIONS FOR USE

## WARNING

If there is any abnormality such as smoke, bad smell or abnormal noise being emitted from the machine, immediately turn OFF the main power switch and unplug the power cord from the receptacle to stop operating it. 

- Using the machine in abnormal conditions could result in fire or accidents.

In case of abnormality

1. Turn OFF the main power switch.
2. Unplug the power cord from the receptacle.
3. Contact your nearest dealer.

**Do not leave the power cord plugged in improperly or covered with dust.** 

- Doing so could result the power cord periodically.

## CAUTION

**Do not use this product anywhere other than industrial areas.** 

- Using in a residential area or an area next to a residential area could affect signal reception of radios, television sets, telephones, etc..
- Do not give shock the surface of glass products.

- Please do not play this game if
  - When you do drinking;
  - When your physical condition is not normal;
  - When you are in pregnancy;
  - When you have on a pulse controller;
  - When you have recently experienced a cramp or fainting away while watching TV.
- Avoid excessive force/shock while playing/moving the game.
- While do games, pay attention to surrounding.

**Do not plug or unplug the power cord with wet hands.** 

**In handling the power cord, follow the instructions below.** 

- |   |  |
|---|--|
| • Do not damage the power cord.           | • Do not modify the power cord.            |
| • Do not bend the power cord excessively. | • Do not twist the power cord.             |
| • Do not heat the power cord.             | • Do not pull the power cord.              |
| • Do not bind the power cord.             | • Do not stand on the power cord.          |
| • Do not sandwich the power cord.         | • Do not drive a nail into the power cord. |

**If the power cord or power plug becomes damaged, stop using the machine immediately and ask your nearest dealer to replace the parts.**

# PRECAUTIONS FOR USE

## ⚠ WARNING

Be sure to turn OFF the main power switch and unplug the power cord from the receptacle before inspecting or cleaning the machine.



When replacing parts, be sure to use parts of the correct specifications. Never use parts other than the specified ones.



Opening inside the machine shall be done by machine specialist only as high electric current is being sent inside. For game machine with monitor, a care should be taken while opening its back door. If not, a damage to the inside parts or the monitor may occur.



If the sub power switch of the service panel is turned OFF without turning OFF the main power switch of the power supply unit, some parts in the units remain live. When opening the back door, be sure to turn OFF the main power switch and unplug the power cord from the receptacle.



Strictly refrain from disassembly and repair of parts which are not indicated in this manual, as well as settings and remodeling.



To clean the game machine, wipe it with a soft cloth dampened in a neutral detergent.

- Using thinner or other organic solvent or alcohol may decompose the material.
- Electrical shock or equipment failure could be caused by water entering the inside of the machine.

## ⚠ CAUTION

Components in the game are sensitive to vibrations and impact. Care should be used when moving and transporting the game machine.



Be sure not to let the machine tip over.

Before moving the machine, be sure to turn OFF the main power switch, unplug the power cord from the receptacle and remove the power cord from the machine.



Before moving take the machine, off the levelers and move it on the casters.

Avoid excessive force while moving the machine.

.....

## PRECAUTIONS IN HANDLING

- When setting up, inspecting, maintaining, moving or transporting this product, follow the procedures and instructions set forth in this manual and perform such work safely.
- Do not set up, handle, inspect, maintain, move or transport this product under conditions equivalent to the condition of "WARNING" or "CAUTION" specified in this manual.
- If a new owner is to have this product as a result of transfer, etc., be sure to give this manual to the new owner.

# **CONTENTS**

## **1. SPECIFICATION AND DIMENSION**

- 1-1. DIMENSION
- 1-2. SPECIFICATION
- 1-3. NAME OF PARTS & STICKER LOCATION

[ COMPONENTS ]

## **2. INSTALLATION**

## **3. CAUTIONS**

## **4. PRODUCT CHARACTER**

## **5. SETUP MENU**

- 5-1. SETUP METHOD
- 5-2. SETUP MODE
- 5-3. CLEAR MODE
- 5-4. VIEW INT-DATA
- 5-5. TEST MODE
- 5-6. ERROR MODE

## **6. TROUBLESHOOTING**

- 6-1. IN CASE OF POWER FAILURE
- 6-2. FLUORESCENT LAMP
- 6-3. 3 WAVE LAMP
- 6-4. CONTROL PANEL LDC DISPLAY
- 6-5. FND & LED DISPLAY
- 6-6. SOUND
- 6-7. COIN SELECTOR
- 6-8. TICKET DISPENSOR
- 6-9. WHEEL
- 6-10. BALL ELEVATOR
- 6-11. BALL NOT A HIT
- 6-12. LAMP BUTTON

## **7. REPLACEMENT METHOD OF CONSUMABLE PARTS**

- 7-1. REPLACEMENT OF MOTOR & SENSOR
- 7-2. REPLACEMENT OF MAIN BOARD
- 7-3. REPLACEMENT OF PCB
- 7-4. REPLACEMENT OF MICRO SWITCH
- 7-5. REPLACEMENT OF LAMP

## **8. PART LIST**

- 8-1. EXPLODED VIEW
- 8-2. LIST
- 8-3. PICTURE

## **9. WIRING DIAGRAM**

# 1. DIMENSION & SPECIFICATION

## 1-1. DIMENSION

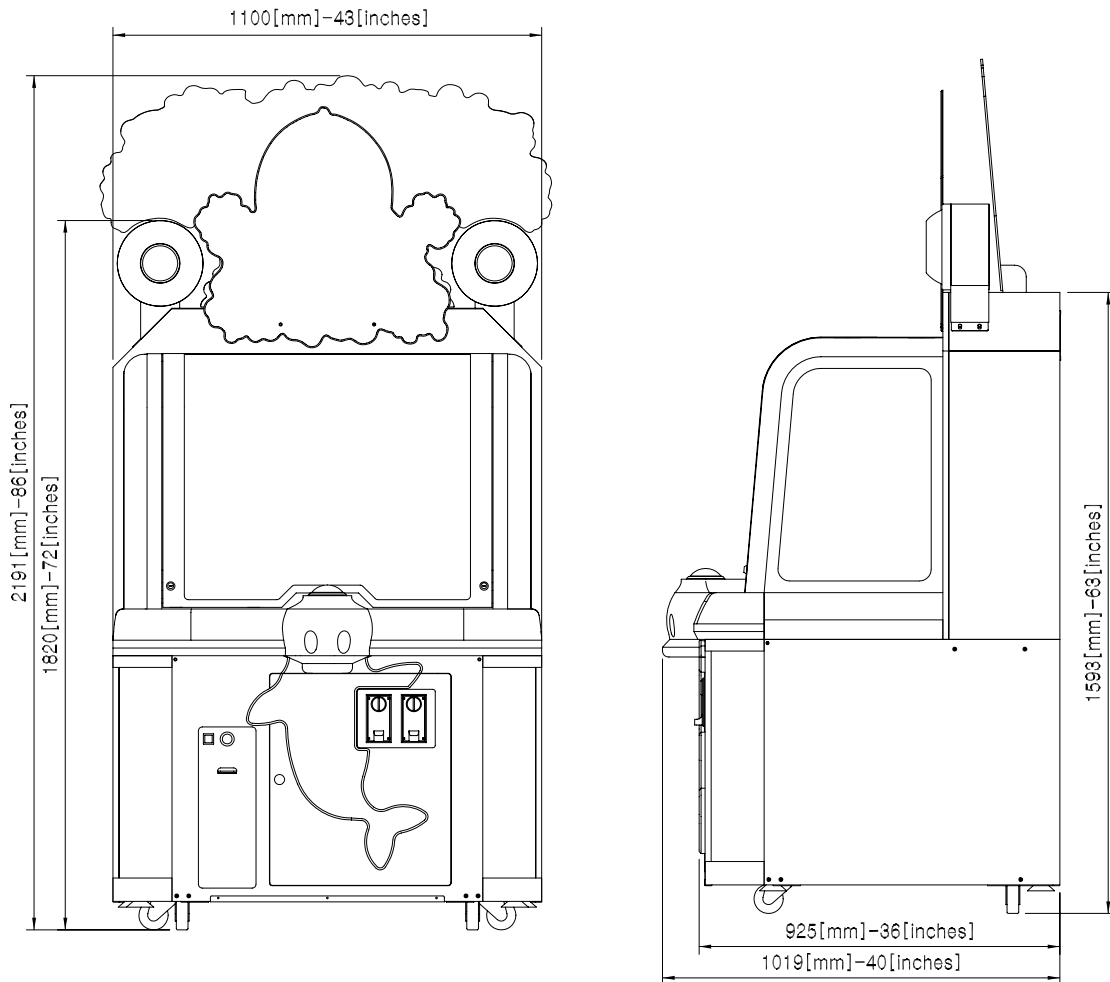

## 1-2. SPECIFICATION

DIMENSION (W x D x H)	1100 x 1019 x 1593 (mm)	
PACKING DIMENSION (W x D x H)	1150x 1080 x 1790 (mm)	
WEIGHT (kg)	200 kg	
VOLTAGE	AC 110V	AC 220V
FREQUENCY RANGE	60 Hz	60 Hz
CONSUMPTION	300 W	

# 1-3. NAME OF PARTS & STICKER LOCATION

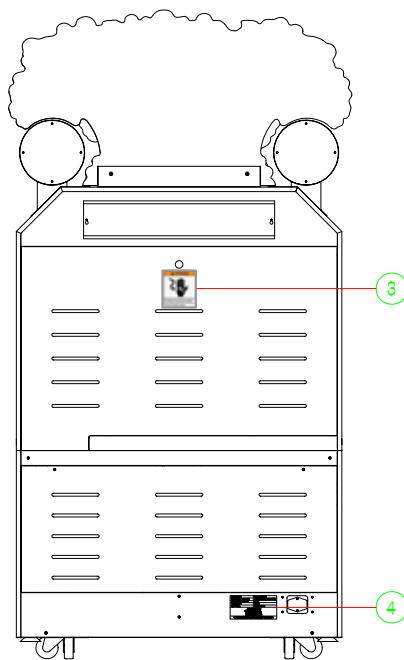
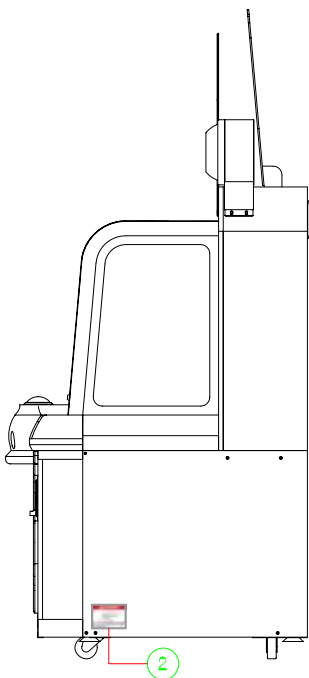
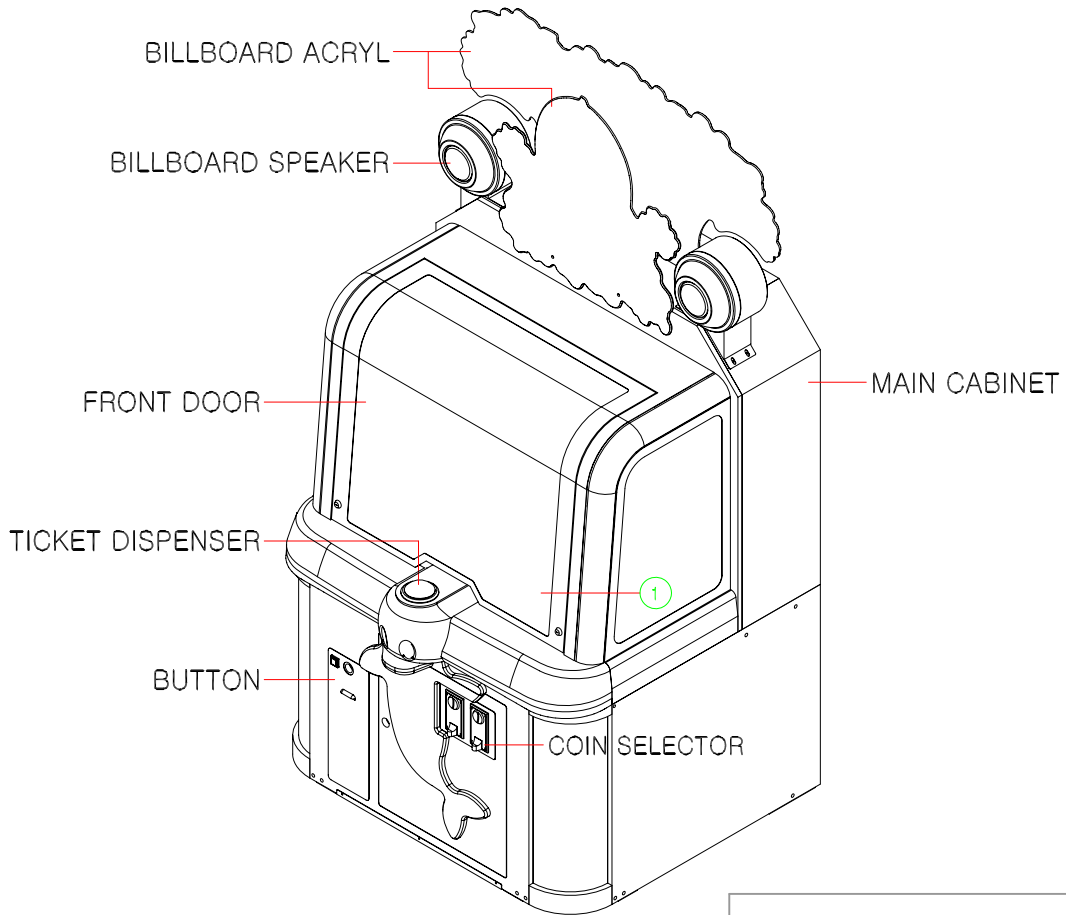

1

**CAUTION** Please be noted that the machine need to be leveled during installation.

2

**CAUTION**

When installing the product, set the 4 leg levelers evenly on the floor and make sure that the product is installed safely in a horizontal position.  
① Please the set leveling lever(s) can be locked.

3

**WARNING**









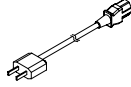

Change service personnel status. Please open the product. Be careful of electric shock.

4

MODEL NAME	DOLPHIN SHOW
POWER REQUIREMENTS	AC 220V ± 5%, 50Hz ~ 60Hz
POWER CONSUMPTION	300W
WEIGHT (KG)	230KG
MODEL NO.	GD080000001
XXXXXX-XXXXXXXXXX Koyang-si, Kyonggi-do, Korea Phone:82-31-808-2114	



# COMPONENTS

NO.	PART NAME	SPEC.	QTY
1	WRENCH	3mm, 4mm 	각 1개
2	AC POWER CORD	110V 	1
3	KEY	6001 	2
4	KEY	7001 	2
5	BILLBOARD SPEAKER MOLDING ASS'Y	- 	2
6	BILLBOARD REAR ACRYL BRACKET	- 	1
7	BILLBOARD LAMP COVER ACRYL	- 	1
8	3 WAVE-LAMP	- 	2
9	BALL	- 	20
10	FLAT HEAD BOLT	M6x20L 	10
11	FLAT HEAD BOLT	M6x15L 	2
12	MANUAL	- 	1

## 2. INSTALLATION

- Need to have installation place.  
Maintenance Zone & Play zone should have at least 1500mm x 1700mm each.
- Please do not install the equipment in the place where it is exposure to direct sunlight in order to avoid malfunction of sensor. Indoor intensity of illumination need to be 200lux~300Lux.

### IMPORTANT

- Once you set up the machine with required game-play area, when installing this product, set the 4 leg levelers evenly on the floor and make sure that the product is installed stably in a horizontal position. Otherwise the set winning percentage can be twisted.

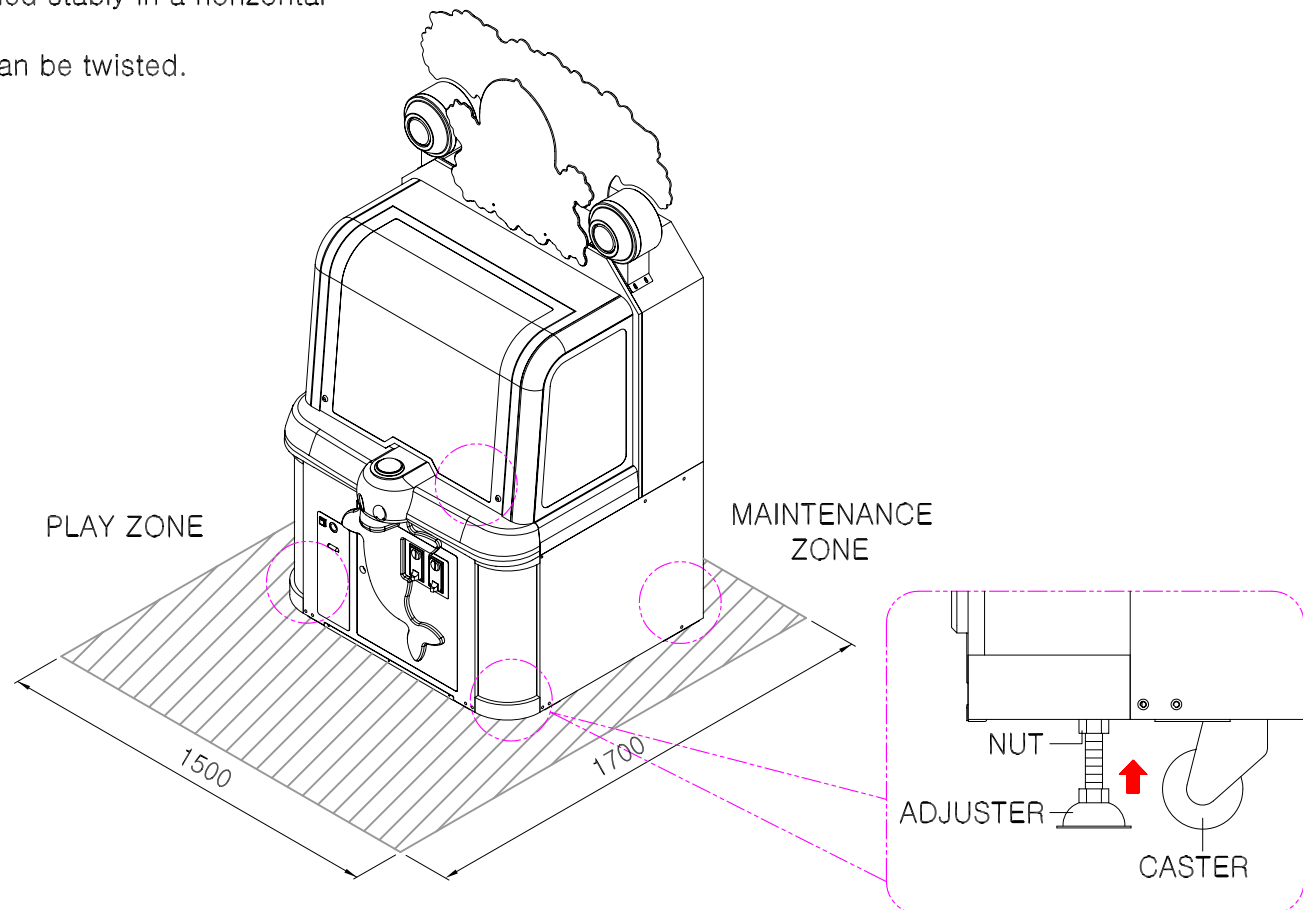

## PACKAGE REMOVAL



DOLPHIN PART



SEESAW PART



ELEVATOR PART



SERVICE PART

- [1] ~ [4] Remove package for each parts.

## [ How to installation ]

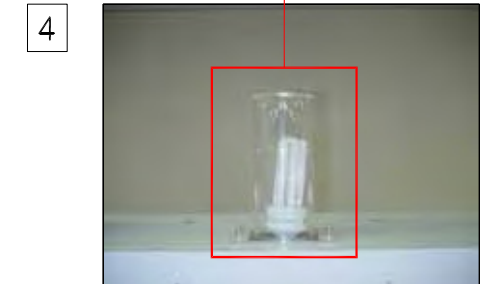
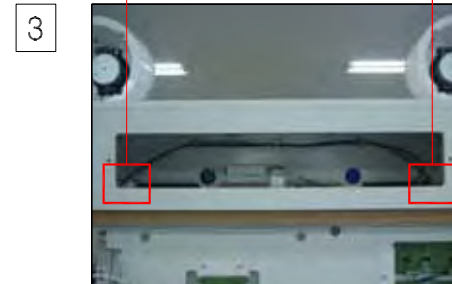

- The machine is shipped as Picture [1]
- Please assemble "BILLBOARD SPEAKER MOLDING ASS'Y" like picture ① M6x20L [6개소]
- Open "UPPER CABINET REAR COVER", then connect "BILLBOARD SPEAKER SPEAKER" connector. ②
- After connecting 3 wave-lamp in upper Billboard like picture ③, assemble "ACRYL COVER" and "BILLBOARD LAMP BRACKET" M4 Bolt [2개소]
- Assemble BILLBOARD FRONT and REAR ACRYL like picture ④ ⑤ M6x20L [4개소]
- Both the ball to open the front door and pour Shin, turn it on.

### 3. CAUTIONS

---

3-1. Please use supplied ball only.

3-2. Do not wash ball with water.

3-3. Please be careful when "Ball loading bar" is (dis)assembled.

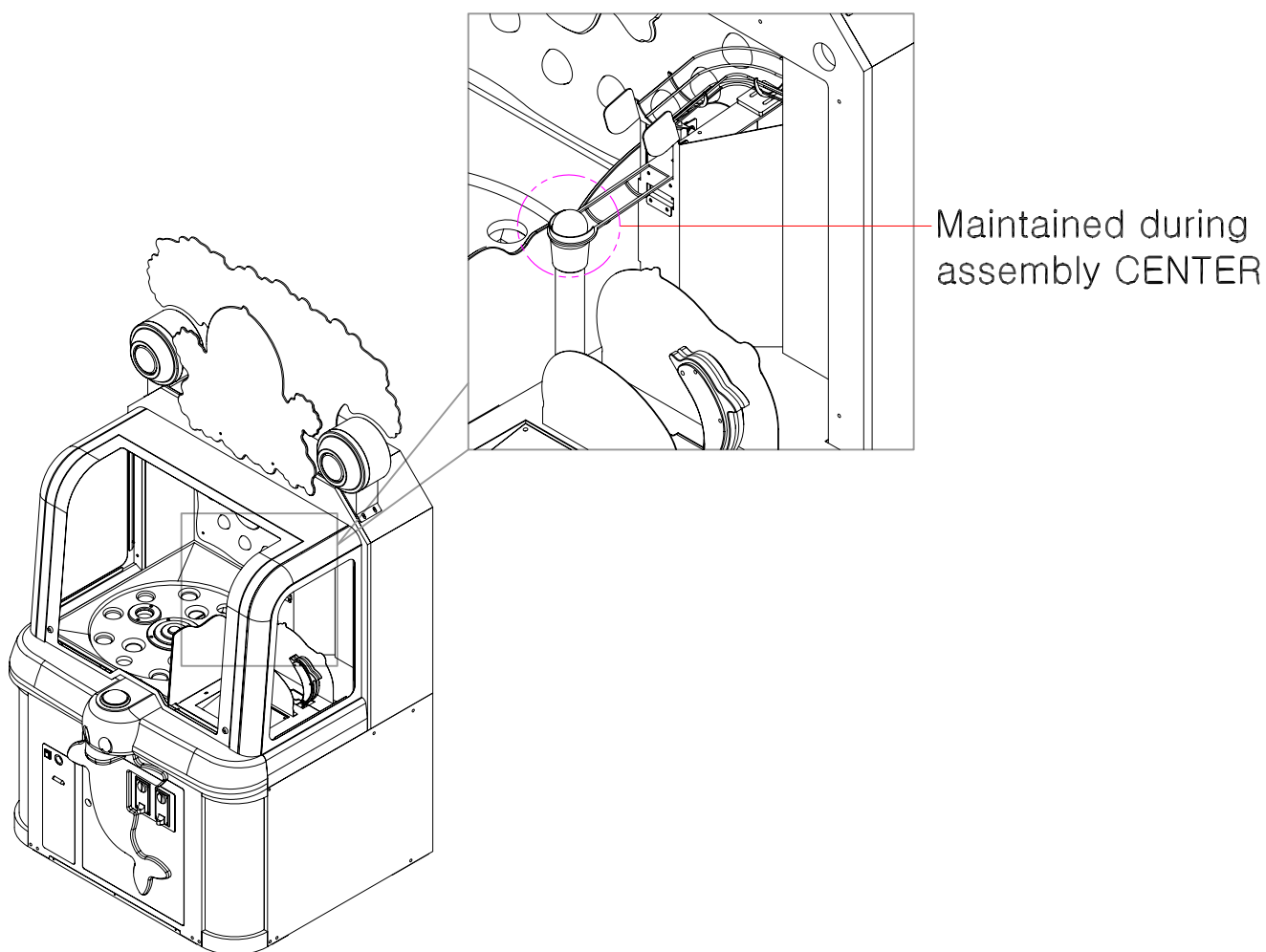

## **4. PRODUCT CHARACTER**

---

- Family friendly ticket redemption game in the base cute dolphin theme.

### **4-1. FRIENDLY DOLPHIN THEME**

- Mysterious dolphin theme which is familiar to all player make user to access to this game easily.

### **4-2. INTUITIONAL GAME**

- Player easily learn that "dolphin hit a ball and it goed to a hole" at a glance. Every player gets any ticket without failure. Especially, this dolphin theme is friendly to child.

### **4-3. FABULOUS EFFECT OF SOUND & DISPLAYING**

- Cheerful sound and magnificent lighting are given during playing. Also harmonious narration adds up to the musement.

### **4-4. INTERESTED BOUNCING BALL**

- It gives more interesting for player to watch bouncing ball un-expected way. If you aim good and are lucky you may get a big ticket.

### **4-5. EXCITING SHOW TIME**

- When ball goes into rainbow color hole, relevant ramp is lit up. You have a exciting show time when 7light lit up.

### **4-6. EXCITING SHOW TIME**

- This show time avoids momotonous and repeated game and gives player game among the game with fabulous sound & lightning effect.

# 5. SET UP

## 5-1. SETUP METHOD

### (1) OPERATIONAL MODE

- 1 There is "Control panel" when you open front door.



PICTURE A

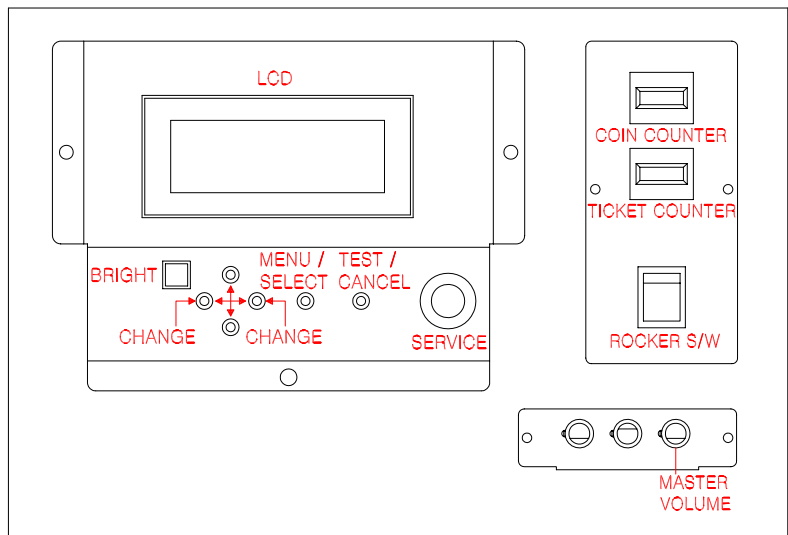

[ CONTROL PANEL ]

#### [ View / Clear tickets during game ]

- VIEW TICKETS : Press <- / -> button during playing.
- CLEAR TICKETS : When you press "SELECT" button during View tickets.

Dispensing ticket is temporarily stopped. Then you press "select" button again. It clear remained ticket(s).

#### [ OPERATION MENU ]

- Press **MENU** button [ **SELECT** button : ACCESS ]
- **SETUP MODE** : Set up mode
- **CLEAR MODE** : Clear mode
- **VIEW INT-DATA** : Check internal data
- **FACTORY-SETTING** : Factory initialization settings
- **GAME MODE** : Returning to game mode

## 5-2. SETUP MODE

SETUP MODE		← CHANGE VALUE →		
LCD DISPLAY		DESCRIPTION	RANGE	DEFAULT
Credit / Coin		Credit / Rate of coin	1/1, 1/2, 1/3, 1/4, 1/5 2/2, 3/1, 4/1, 5/1	1/2
ShowBalls		The number of ball in show time	1 ~ 30	15
TK-Hole-A1		The score of A1 hole (Internal)	1 ~ 200	100
TK-Hole-A2		The score of A2 hole	1 ~ 200	10
TK-Hole-A3		The score of A3 hole	1 ~ 200	20
TK-Hole-A4		The score of A4 hole	1 ~ 200	50
TK-Hole-A5		The score of A5 hole	1 ~ 200	15
TK-Hole-B1		The score of B1 hole (External)	1 ~ 200	5
TK-Hole-B2		The score of B2 hole	1 ~ 200	12
TK-Hole-B3		The score of B3 hole	1 ~ 200	7
TK-Hole-B4		The score of B4 hole	1 ~ 200	30
TK-Hole-B5		The score of B5 hole	1 ~ 200	5
TK-Hole-B6		The score of B6 hole	1 ~ 200	15
TK-Hole-B7		The score of B7 hole	1 ~ 200	7
TK-Hole-B8		The score of B8 hole	1 ~ 200	12
TK-Hole-B9		The score of B9 hole	1 ~ 200	25
TK-Hole-B0		The score of B0 hole	1 ~ 200	10
HalfTicket		Dispensing one ticket per 2points	OFF, ON	OFF
NO-Ticket		No ticket	OFF, ON	OFF
Hit-Speed		Ball hit rate	1-SS, 2-SN, 3-SF, 4-NS, 5-NN, 6-NF, 7-FS, 8-FN, 9-FF	OFF
SAVE AND EXIT		Save & Exit	SELECT button : RUN	
CANCLE AND EXIT	Cancle & Exit			

### 5-3. CLEAR MODE

CLEAR MODE			
LCD DISPLAY		DESCRIPTION	
CLEAR TICKETS		Erase ticket	SELECT button : RUN
CLEAR GAME-DATA		Erase game data	
EXIT		Exit	

### 5-4. VIEW INT-DATA

VIEW INT-DATA			
LCD DISPLAY			
Games		The number of playing game	
Payout		The amount of dispensed ticket	
AVG Total		The average of dispensed ticket per playing	
AVG Normal		The number of ticket for normal game (AVG Total)	
AVG Show		The number of ticket for show time (AVG Total)	
ShowCycleAvg		Average value of show cycle	
ShowCycleMin		The minimum value of show cycle	
ShowCycleMax		The maximum value of show cycle	
ShowBonusAvg		Average value of show bonus	
ShowBonusMin		The minimum value of show bonus	
ShowBonusMax		The maximum value of show bonus	
*** Noramal Game ***		The ratio of inserting ball per hole during normal game.	
Hole A1 ~ Hole B0		The ratio of inserting ball per hole during normal game. (Hole A1 ~ Hole B0)	
*** Sow Time ***		The ratio of inserting ball per hole during show time.	
Hole A1 ~ Hole B0	The ratio of inserting ball per hole during show time. (Hole A1 ~ Hole B0)		



<b>FACTORY-SETTING</b>
------------------------

Returning to Factory setting (Entire data clear / return to factory setting))
---

SELECT button : Initialize after re-confirmation
--











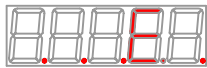
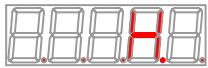
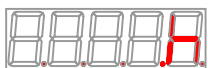

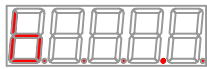



<b>GAME MODE</b>
------------------

Return to Game mode (Exit menu)
---------------------------------

SELECT button : RUN
---------------------



## 5-5. TEST MODE

- In order to access to test mode, keep pressing "TEST" button when turning on machine.

<b>TEST MODE1 : PLACE TEST</b>			
T-1		Location test for FND, LED, SPEAKER and etc.	SELECT: PAUSE/RESUME
T-2		Unit test FND LED and etc.	
<b>TEST MODE2 : INOUT TEST</b>			
Show Bonus FND	 Wheel Encoder 1		 Hole S/W 1  Hole S/W 2
	 Wheel Encoder 2		
Win FND	 Button		 Dolphin Encoder 1  Dolphin Encoder 2
	 SISO Sensor		
	 STAY Sensor		
Free Game FND	 Elevator Encoder		 Ball Out S/W  Elevator Up S/W
	 Coin selector		
Credit FND	 Coin selector		 Ticket Sensor  Ticket Button
	 Coin selector		
WhF		Operate wheel motor normal direction	SELECT : Run CANCEL : Stop
WhB		Operate wheel motor reverse direction	
Elv		Operate elevator motor	
DpF		Operate dolphin motor in reverse direction	
DpB		Operate dolphin motor in normal direction	
TkD		Operate ticket dispenser	
Cnl		ON/OFF income counter	
CnO		Payout counter ON/OFF	
<b>TEST MODE3 : SOUND TEST</b>			
Bxx		BGM Test	SELECT : Play CANCEL : Stop
Fxx		Effect Test	
Vxx		Voice Test	

## 5-6. ERROR MODE [ CRITICAL ERROR : GAME IS STOPPED ]

MAIN ERROR CODE		PART ERROR CODE		EXAMPLES
Er1-x	Coin selector error		Coin signal CLOSE	Coin S/W NC
Er4-x	Wheel encoder error		Encoder signal OPEN	Wheel motor does not work
			Encoder signal CLOSE	Wheel motor does not work
			No encoder origin point	
			No match with Encoder segment number	10EA
Er6-x	Elevator error		No change of Encoder signal	Motor does not work, Jammed
			No signal of upper S/W	No ball
Er7-x	Ball out Error		Ball out S/W OPEN	It does not dispense ball
			Ball out S/W CLOSE	Ball is stuck
			Seesaw sensor signal OPEN	Seesaw is not returned. Ball is stuck.
			Seesaw sensor signal CLOSE	Seesaw is not returned. Ball is stuck.
			Ball staying sensor signal OPEN	Ball is not loaded.
			Ball staying sensor signal CLOSE	
			Ball loading error	Ball is not loaded.
Er8-x	Ball hit error		Encoder signal OPEN	Motor does not work, Jammed
			No encoder starting point	Motor does not work, Jammed
			Malfunction of motor speed	
			Malfunction of motor speed	
			Hitting error	Keep sensing ball staying sensor
Er9-x	Hole S/W error		Inner hole S/W OPEN	
			Inner hole S/W CLOSE	Ball is stuck
			Outer hole S/W OPEN	
			Outer hole S/W CLOSE	Ball is stuck

	Ticket Error	Play is available during this error : The remained ticket is dispensed when you press button after loading ticket.	
			No ticket
			Ticket is stuck

\* This error sign show with the number of ticket turns.

# 6. TROUBLESHOOTING

## 6-1. IN CASE OF POWER FAILURE

\* COMMON : INPUT VOLTAGE CHECK  
WIRING CONNECTION CHECK

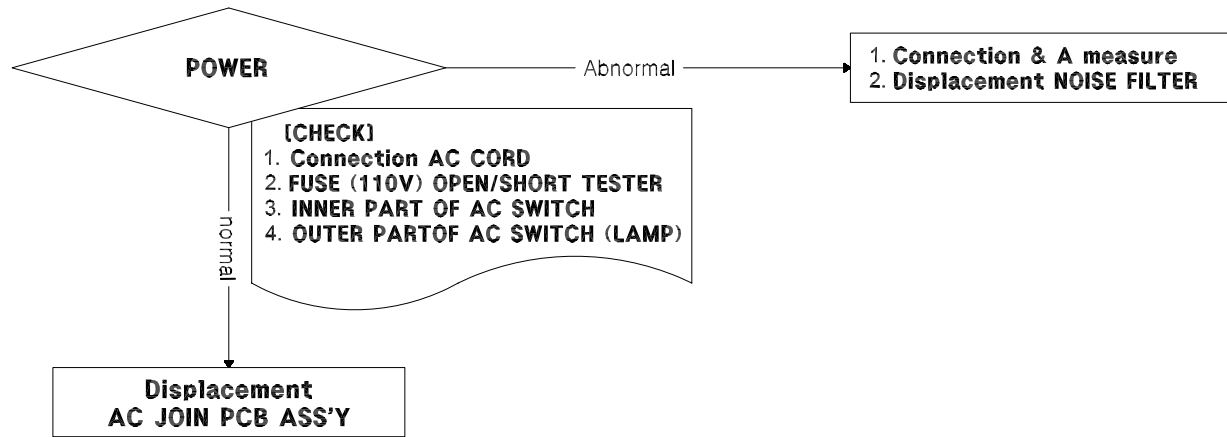

## 6-2. FLUORESCENT LAMP

\* COMMON : INPUT VOLTAGE CHECK  
WIRING CONNECTION CHECK

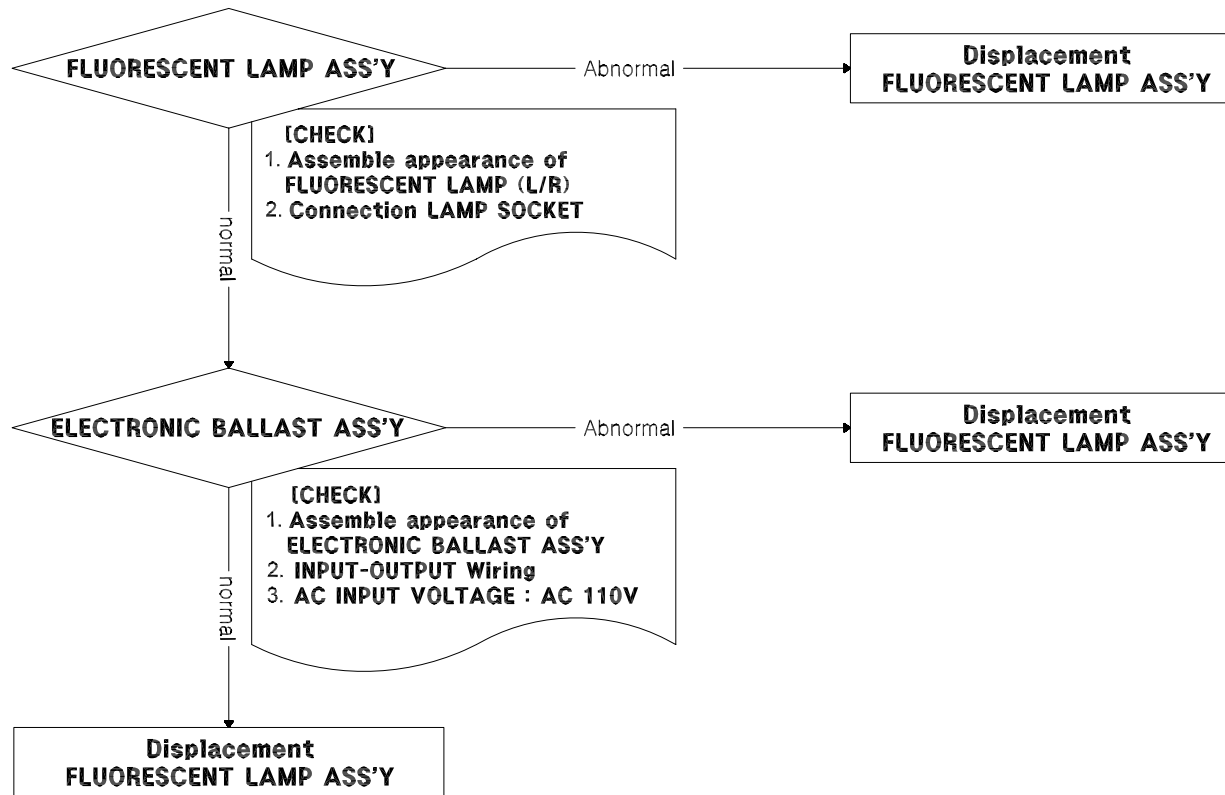

## 5-3. 3 WAVE LAMP

\* COMMON : INPUT VOLTAGE CHECK  
WIRING CONNECTION CHECK

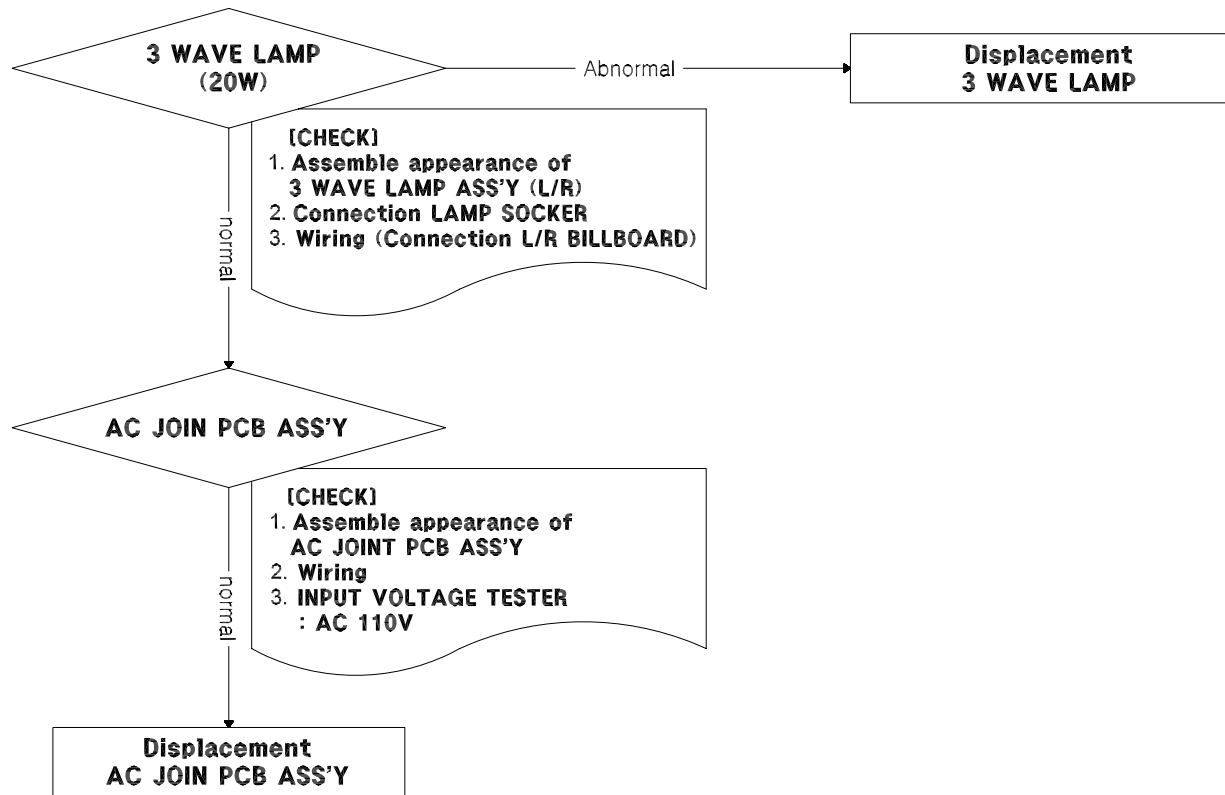

## 6-4. CONTROL PANEL LCD DISPLAY

\* COMMON : INPUT VOLTAGE CHECK  
WIRING CONNECTION CHECK

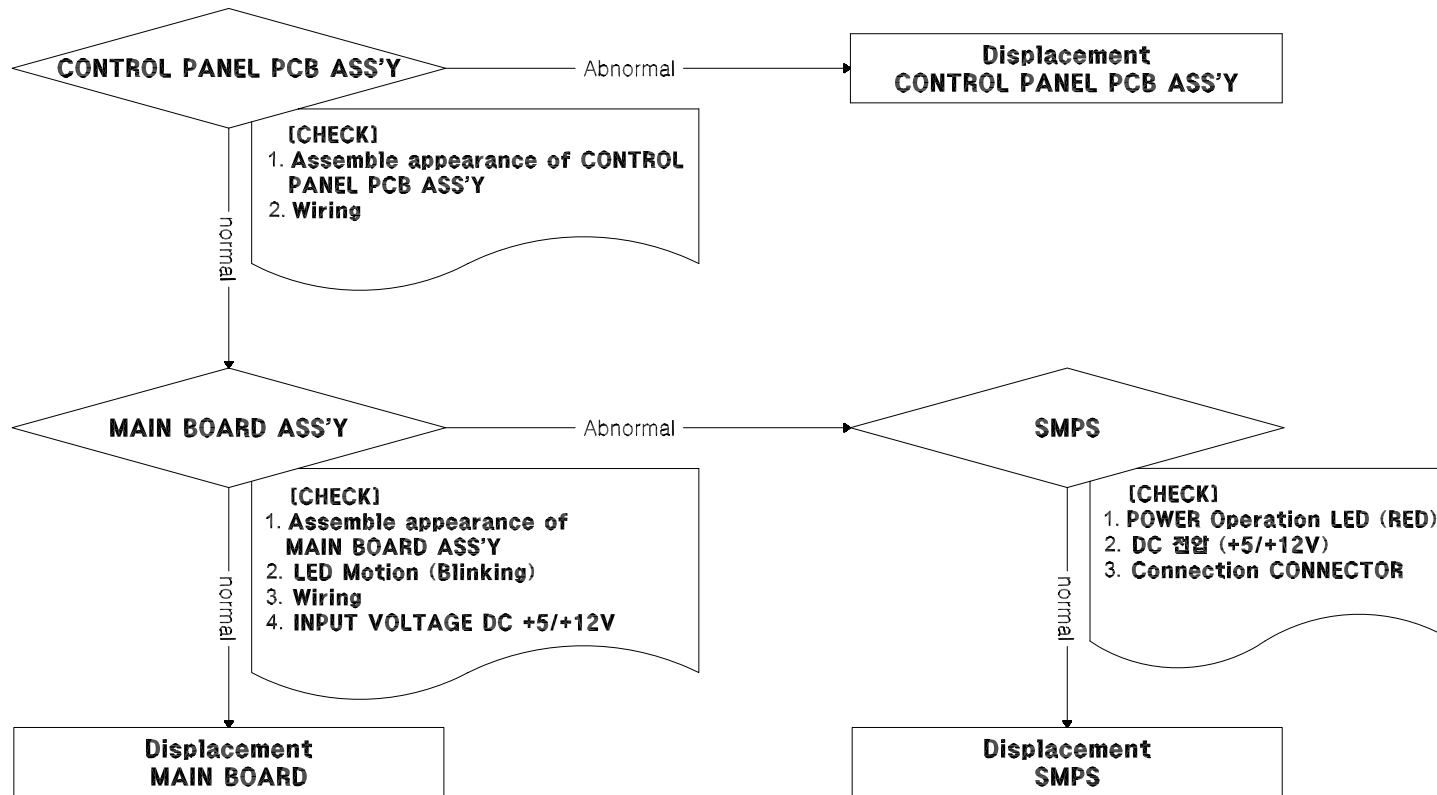



# 6-5. FND & LED DISPLAY

\* COMMON : INPUT VOLTAGE CHECK  
WIRING CONNECTION CHECK

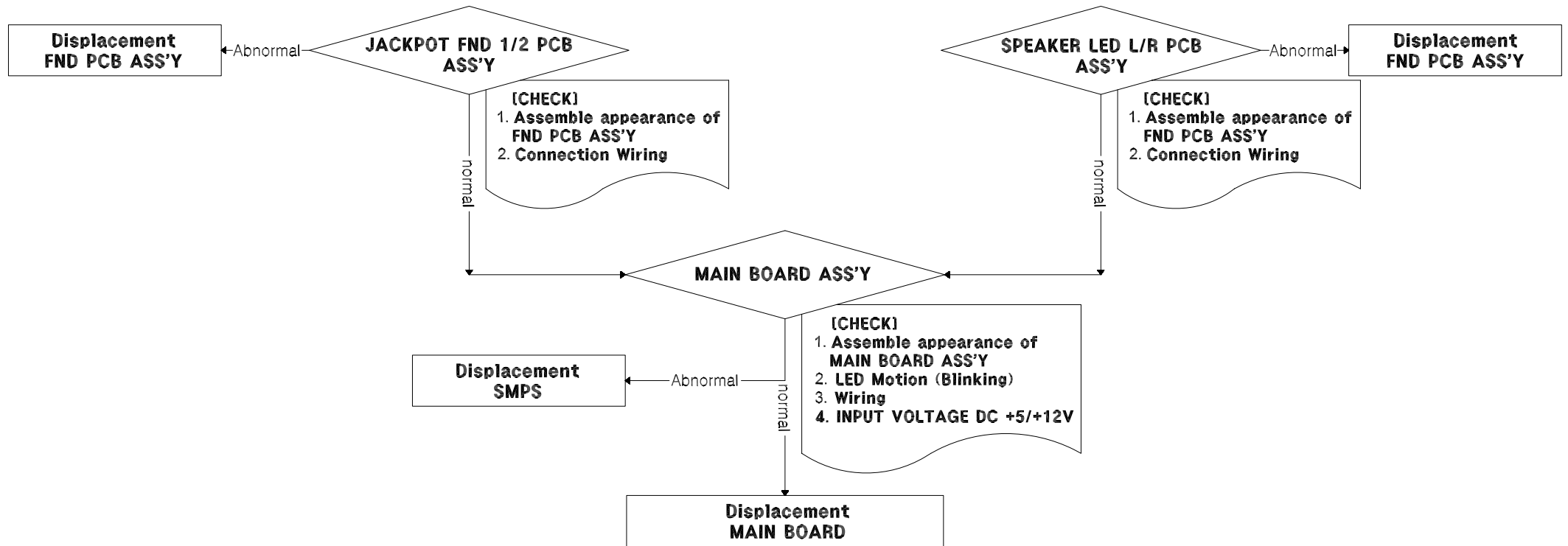

## 6-6. SOUND

\* COMMON : INPUT VOLTAGE CHECK  
WIRING CONNECTION CHECK

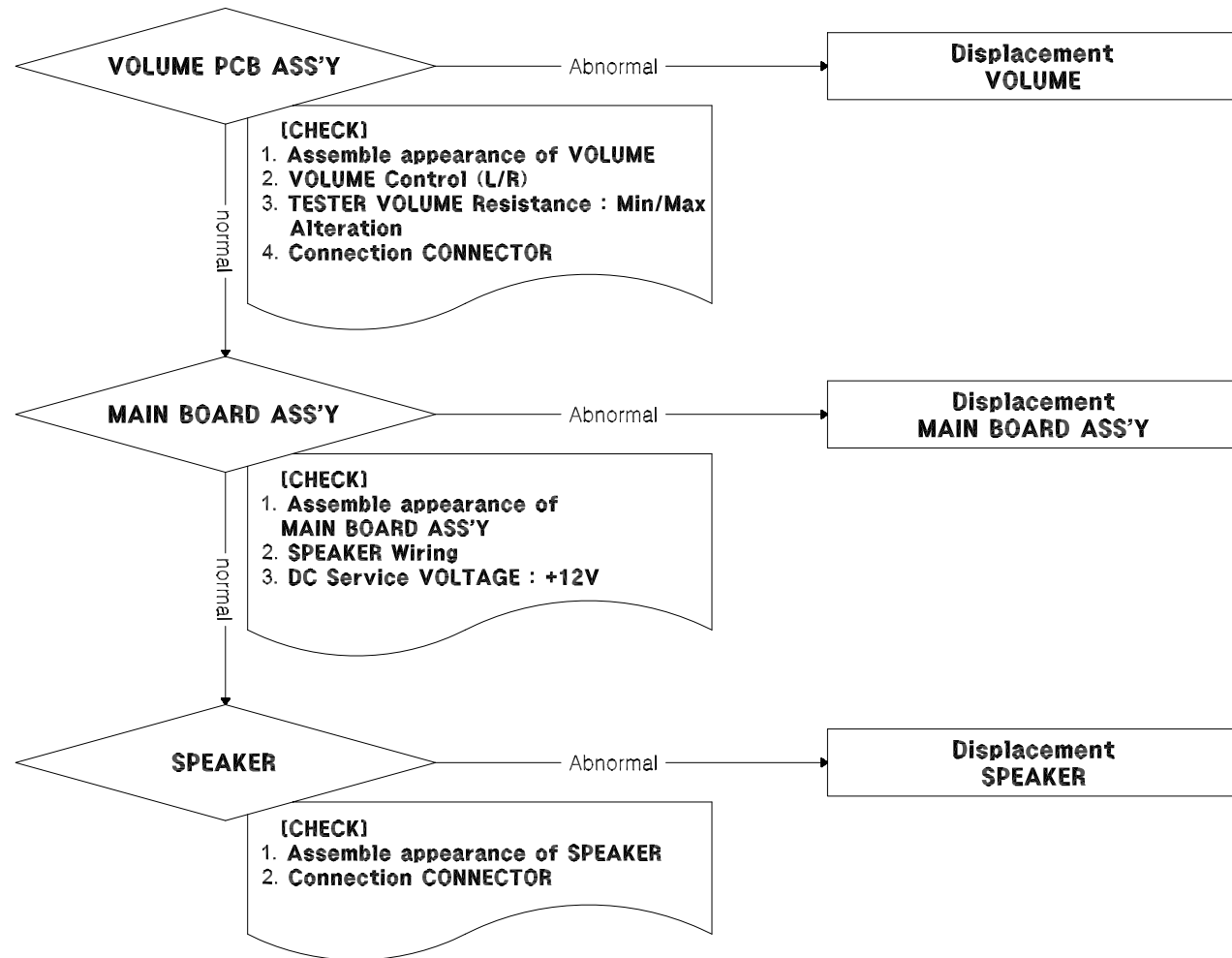

## 6-7. COIN SELECTOR

\* COMMON : INPUT VOLTAGE CHECK  
WIRING CONNECTION CHECK

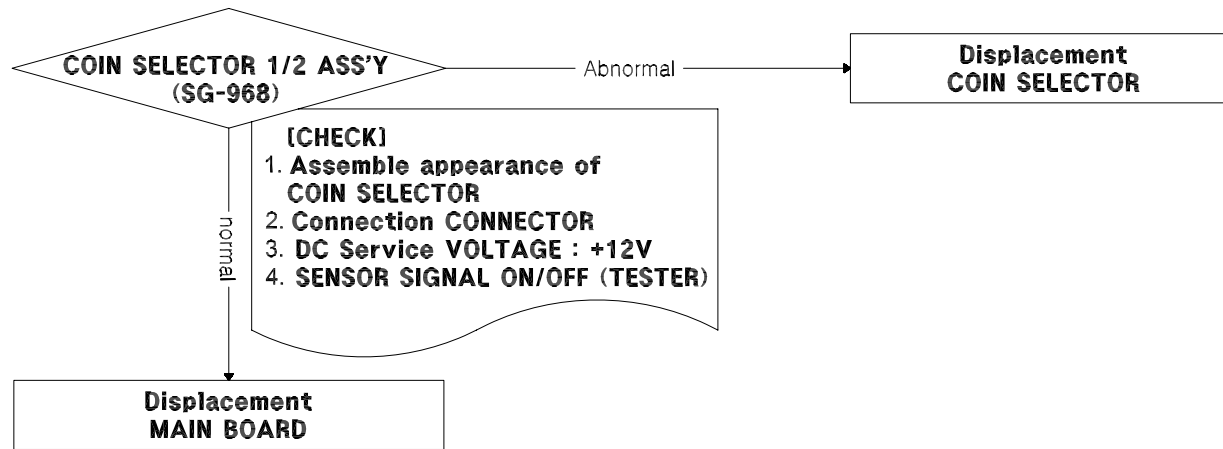

## 6-8. TICKET DISPENSOR

\* COMMON : INPUT VOLTAGE CHECK  
WIRING CONNECTION CHECK

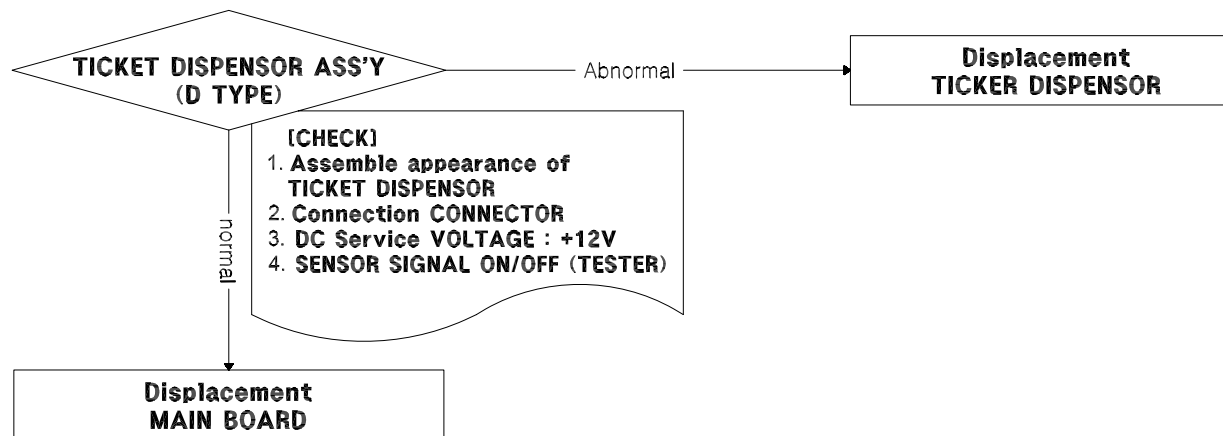

## 6-9. WHEEL

\* COMMON : INPUT VOLTAGE CHECK  
WIRING CONNECTION CHECK

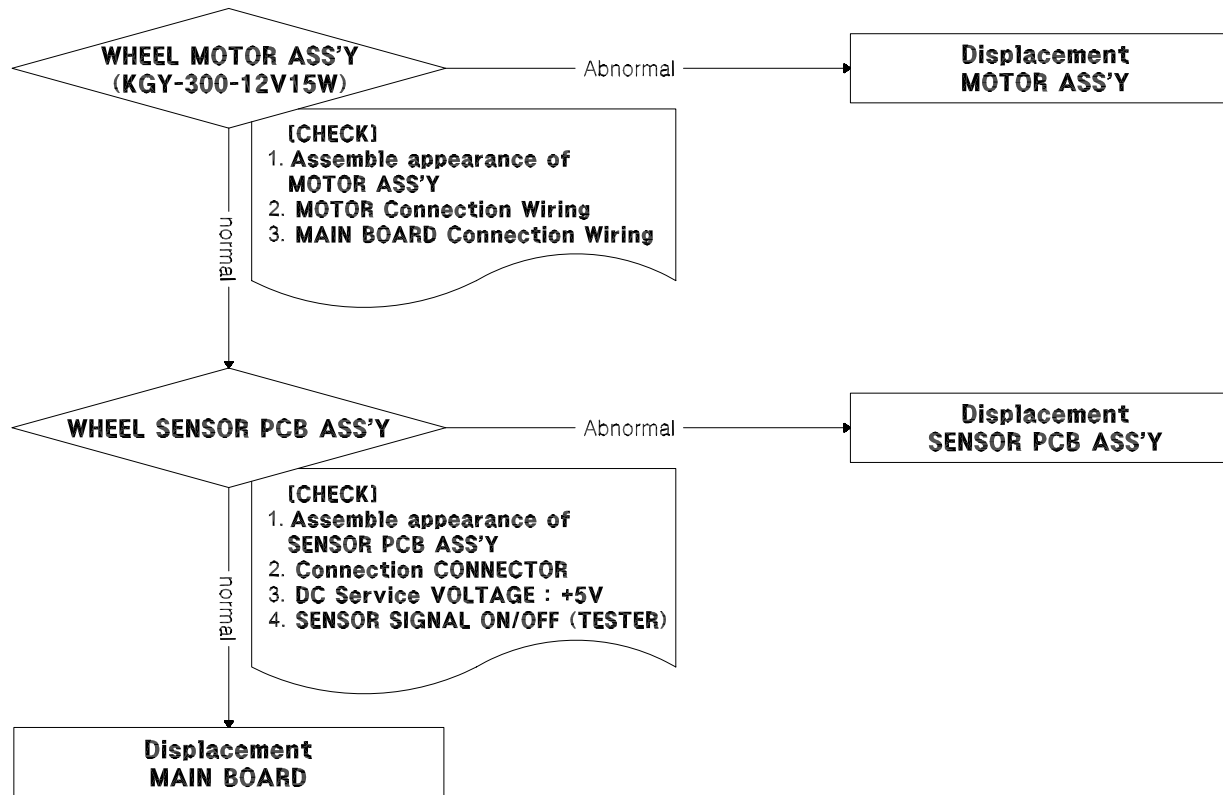

# 6-10. BALL ELEVATOR

\* COMMON : INPUT VOLTAGE CHECK  
WIRING CONNECTION CHECK

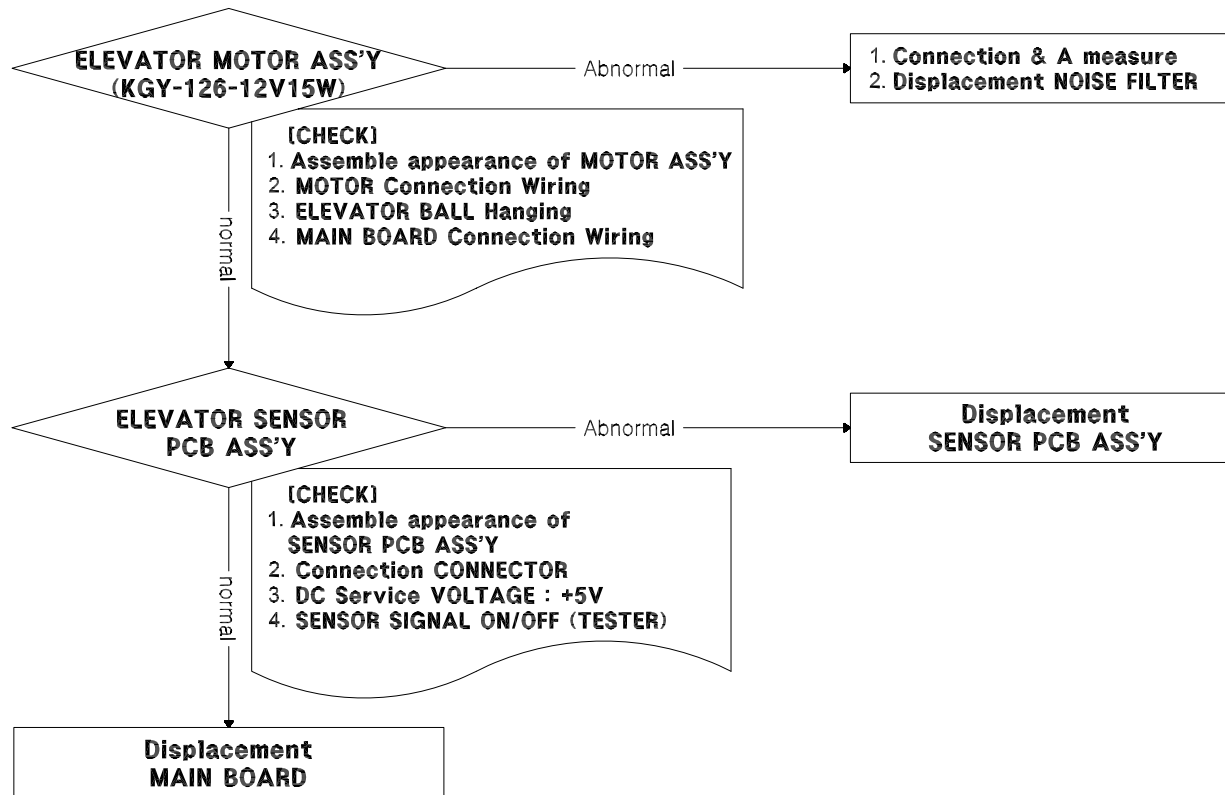

# 6-11. BALL NOT A HIT

\* COMMON : INPUT VOLTAGE CHECK  
WIRING CONNECTION CHECK

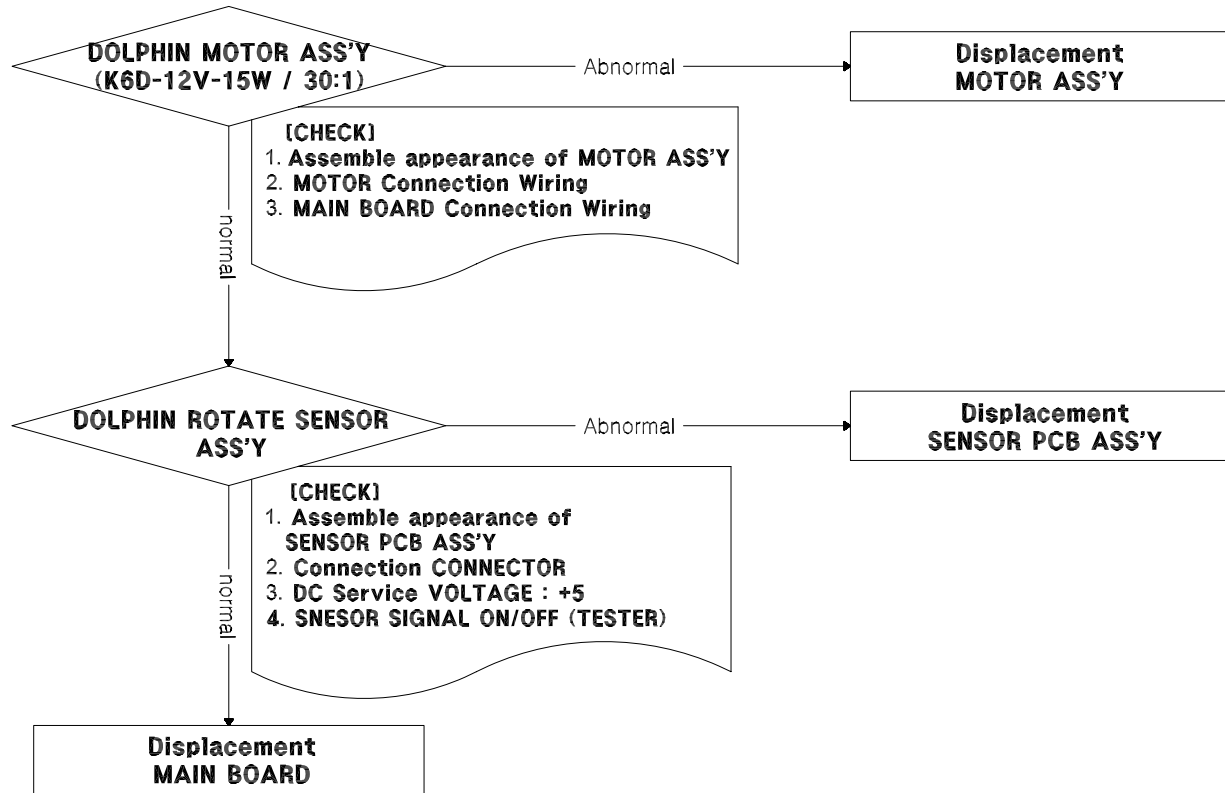

# 6-12. LAMP BUTTON

\* COMMON : INPUT VOLTAGE CHECK  
WIRING CONNECTION CHECK

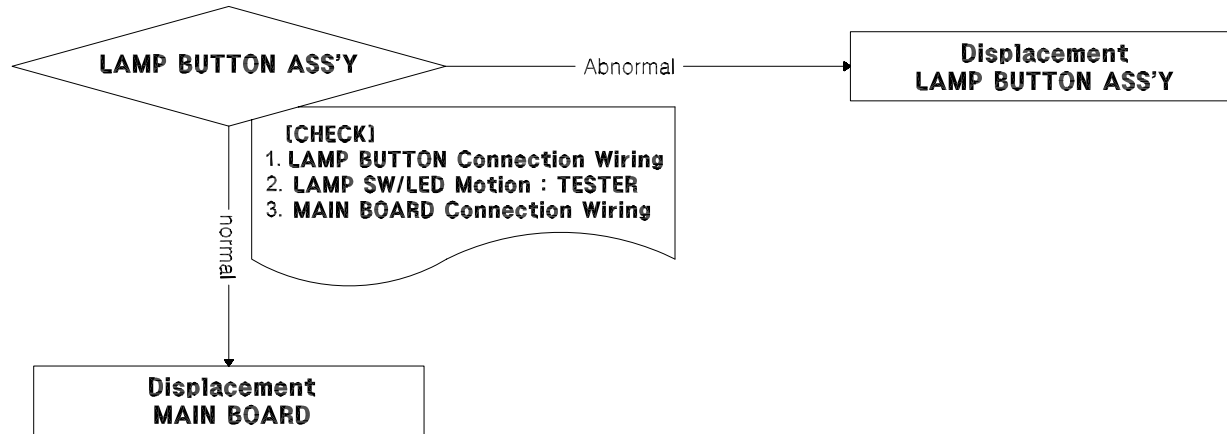

# 7. REPLACEMENT OF CONSUMABLES

## 7-1. REPLACEMENT OF MOTOR & SENSOR

### [ ELEVATOR PART ]

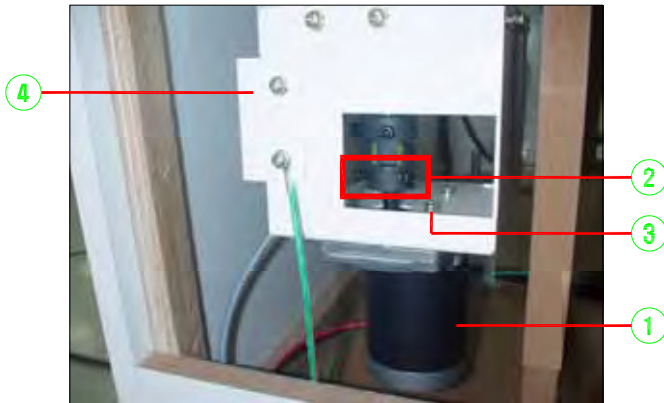

PICTURE A

- (1) Unplugged connector from ① MOTOR and loosen wrench bolt from ② COUPLE-RING
- (2) Replace parts after loosen ③ M4 Bolt(4ea) from MOTOR.
- (3) You may access ④ ENCODER SENSOR after release ELEVATOR ENCODER SENSOR bracket.

NO.	PART NAME	SPEC.	CODE NO.
①	MOTOR	KGY-126-12V15W	MZZZ0MOT051

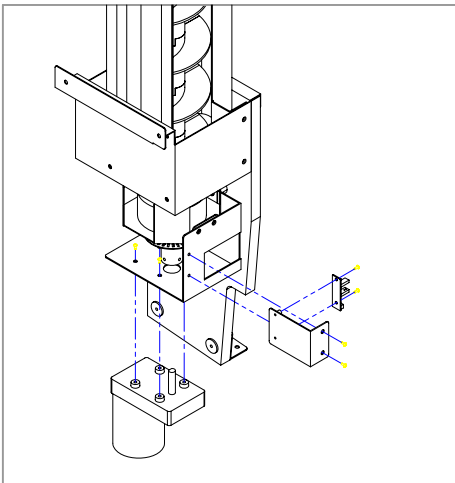

### [ WHEEL MOTOR PART ]

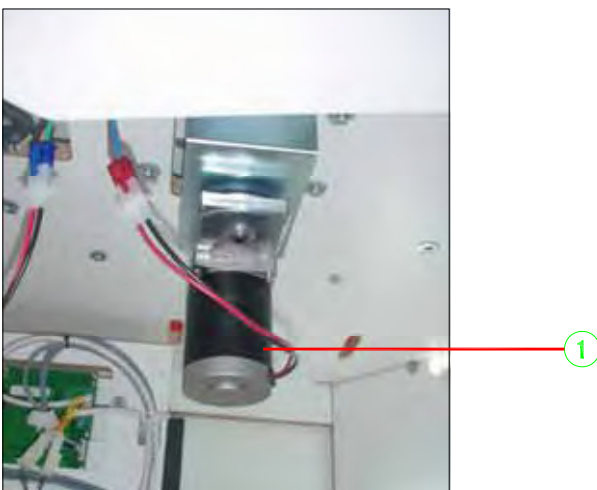

PICTURE A

- (1) You may replace this parts with same way like ① "ELEVATOR PART"

NO.	PART NAME	SPEC.	CODE NO.
①	MOTOR	KGY-300-12V15W	MZZZ0MOT046



## [ DOLPHIN ROTATOR PART ]



PICTURE A

- (1) Please disassemble ② "DOLPHIN ROTATR MOTOR BRACKET" After Unplug connector from ① MOTOR. M6 Bolt (4ea)
- (2) Disassemble ③ "DOLPHIN ROTATE SPER GEAR" from ④ MOTOR after releasing bolt in motor.
- (3) You may replace rotate sensor after take out ⑤ "DOLPHIN ROTATE SENSOR BRACKET" M3 Bolt (4ea)

NO.	PART NAME	SPEC.	CODE NO.
①	DC MOTOR	K6D12V15W	MZZZ0MOT032

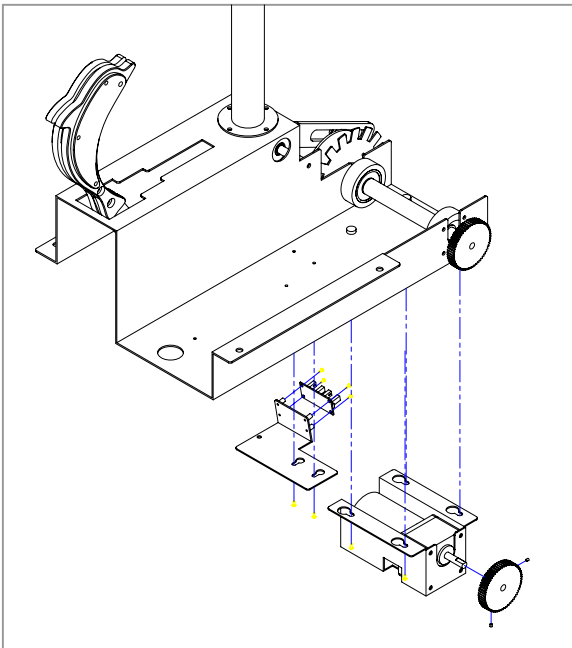

## 7-2. REPLACEMENT OF MAIN BOARD

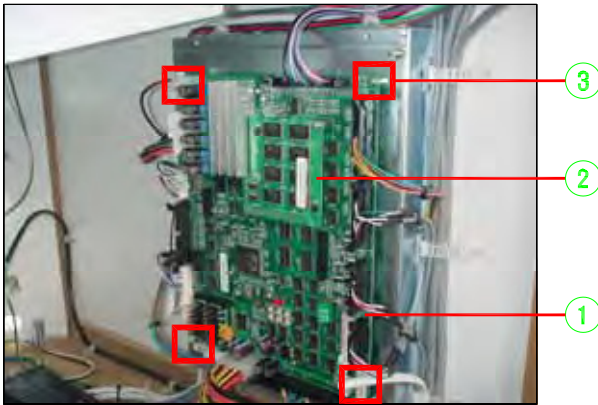

PICTURE A

- (1) You may find ① MAIN BOARD when you open lower backdoor of cabinet.
- (2) Unplug all connected cable from Main board. Replace board after taking out ② M3Bolt (4ea).

NO.	PART NAME	SPEC.	CODE NO.
②	PUBLIC MAIN PCB ASS'Y	KGY-126-12V15W	ADOS0PCB001
③	SOUND ROM PCB ASS'Y		ADOS0PCB002

## 7-3. REPLACEMENT OF PCB

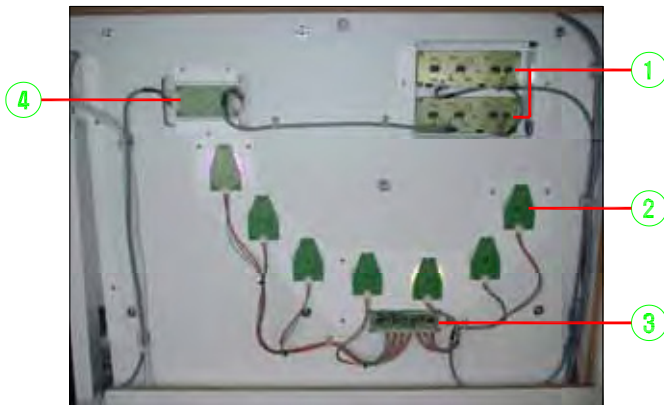

PICTURE A

- (1) There are ① JACKPOT FND PCB ASS'Y, ② SHOW TIME LED PCB ASS'Y, ③ SHOW TIME LED CONTROL PCB ASS'Y, ④ CREDIT FND PCB ASS'Y inside of upper backdoor. You may change board after unplug connector.

NO.	PART NAME	SPEC.	CODE NO.
①	JACKPOT FND PCB ASS'Y	-	ADOS0PCB004
②	SHOW TIME LED PCB ASS'Y	-	ADOS0PCB006
③	SHOW TIME LED CONTROL PCB ASS'Y	-	ADOS0PCB007
④	CREDIT FND PCB ASS'Y	-	ADOS0PCB005

## 7-4. REPLACEMENT OF MICRO SWITCH



PICTURE A

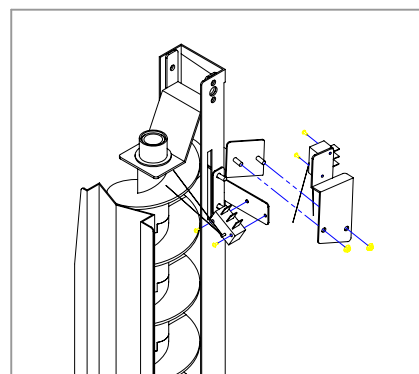

- (1) You may find ① ELEVATOR COLOR SENSOR BRACKET, ELEVATOR SWITCH BRACKET inside of upper backdoor. and you can change relevant Micro Switch after removing bracket. - M4 Nut (4ea), M3 Bolt (4ea)

NO.	PART NAME	SPEC.	CODE NO.
①	MICRO SWITCH	CNR-300-12V15W	MELE0MIC002

## 7-5. REPLACEMENT OF LAMP

### [ BILLBOARD PART ]

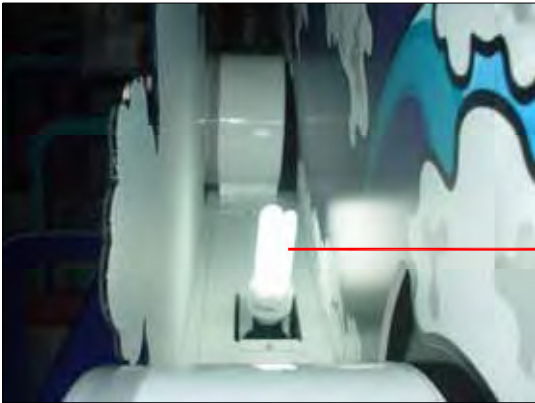

PICTURE A

- (1) You may change ① 3 WAVE-LAMP after disassemble ② ACRYL around the lamp.

NO.	PART NAME	SPEC.	CODE NO.
②	3 WAVE LAMP	3 WAVE (110-20W)	MELE0LAM005

① ②

### [ LOWER CORNER PART ]



PICTURE A

- (1) Disassemble ① "LOWER CORNER ACRYL BRACKET" from front cabinet. (2ea x M6bolt) and change fluorescent light.

NO.	PART NAME	SPEC.	CODE NO.
③	FLUORESCENT LAMP	-	MELE0LAM002

② ③

①

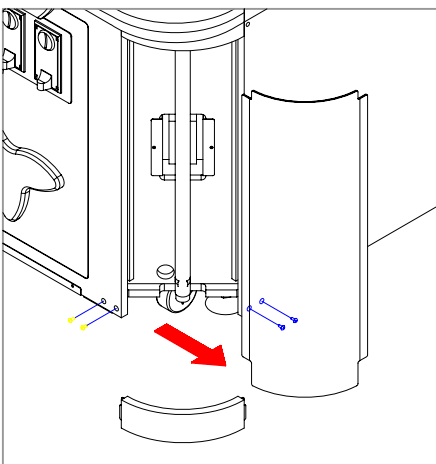

# 8. PARTS LIST

## 8-1. EXPLODED VIEW

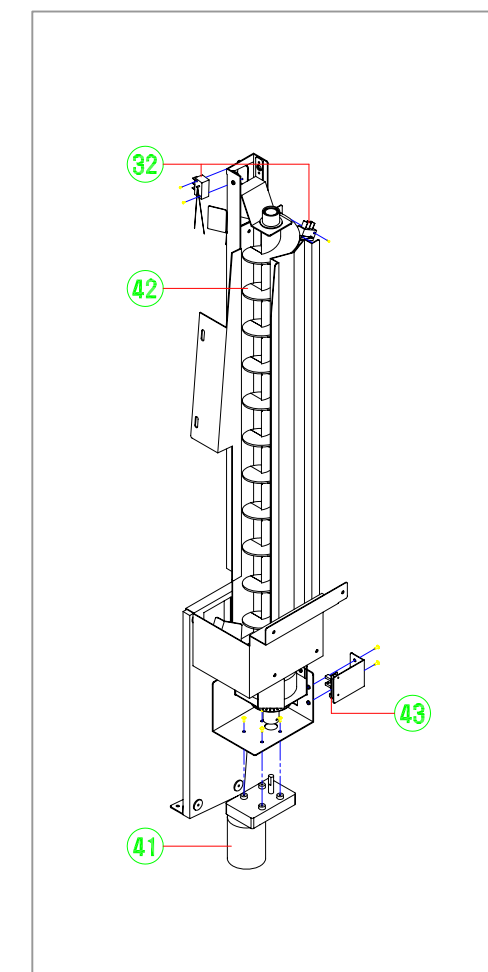
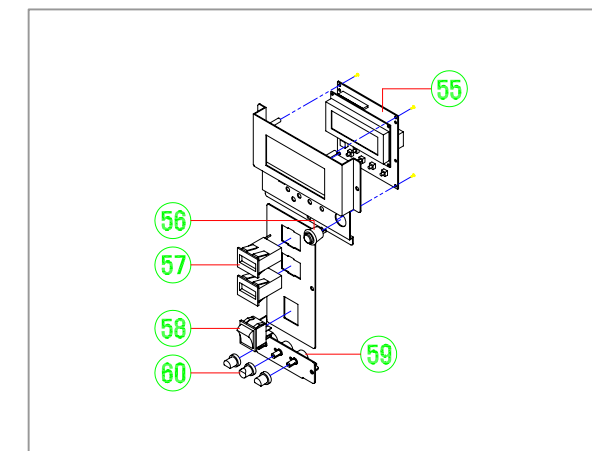
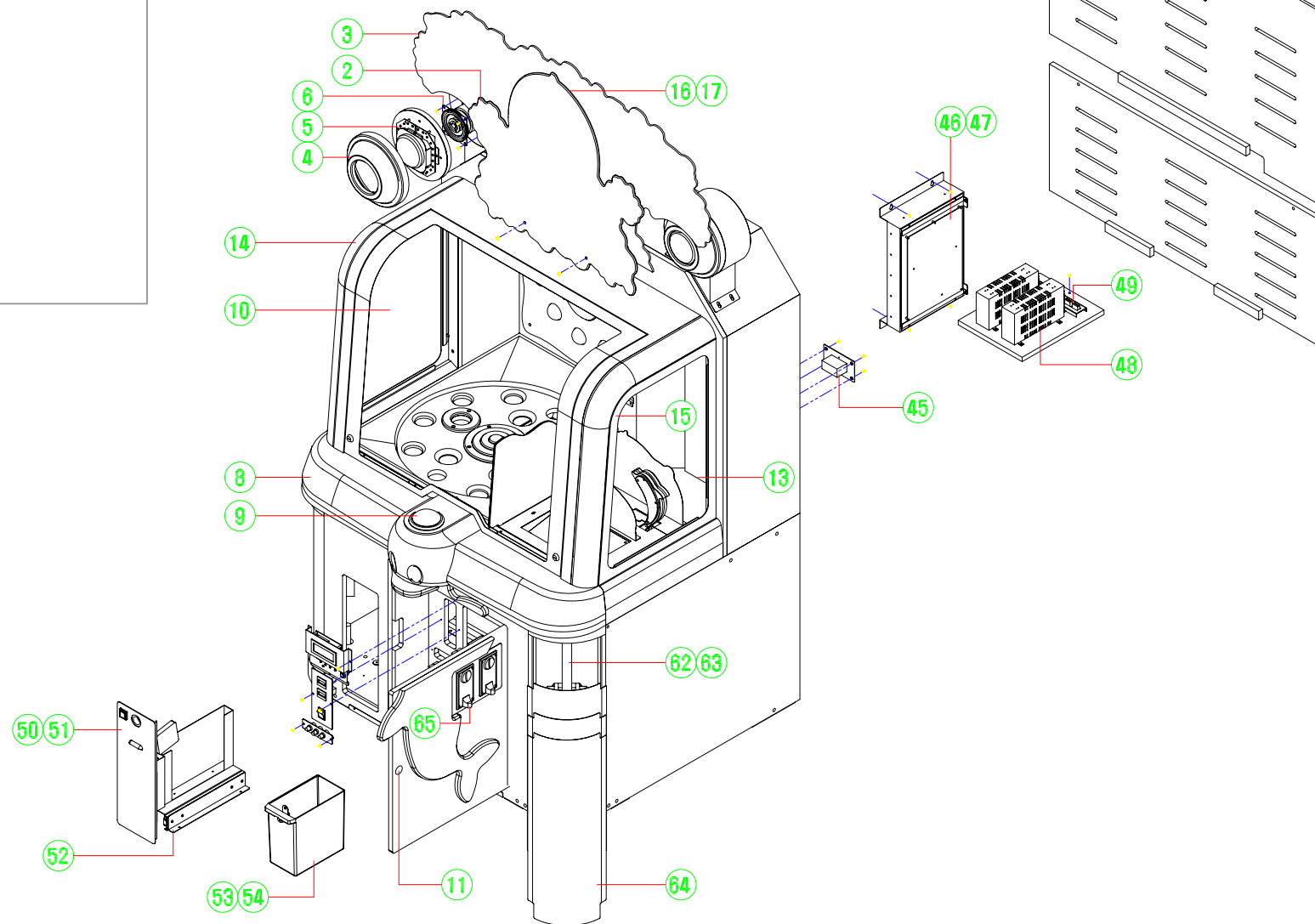
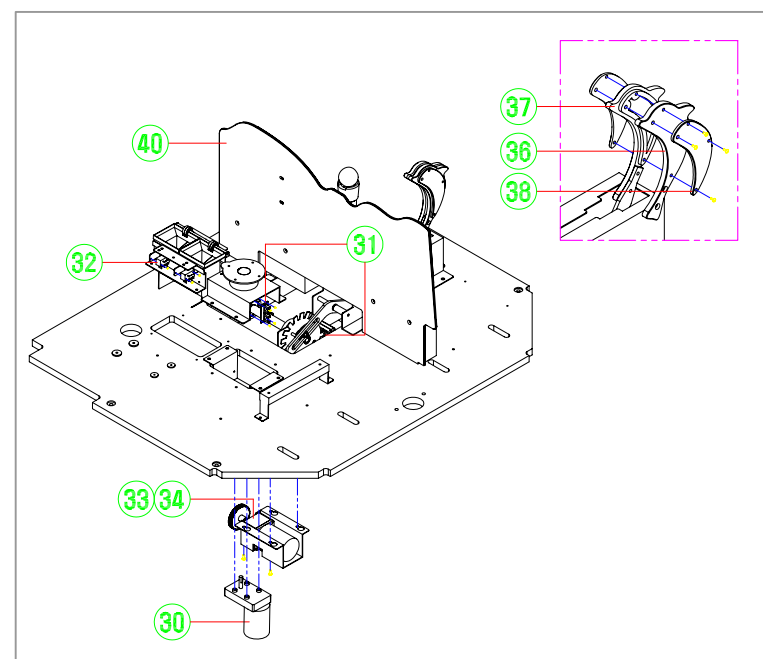
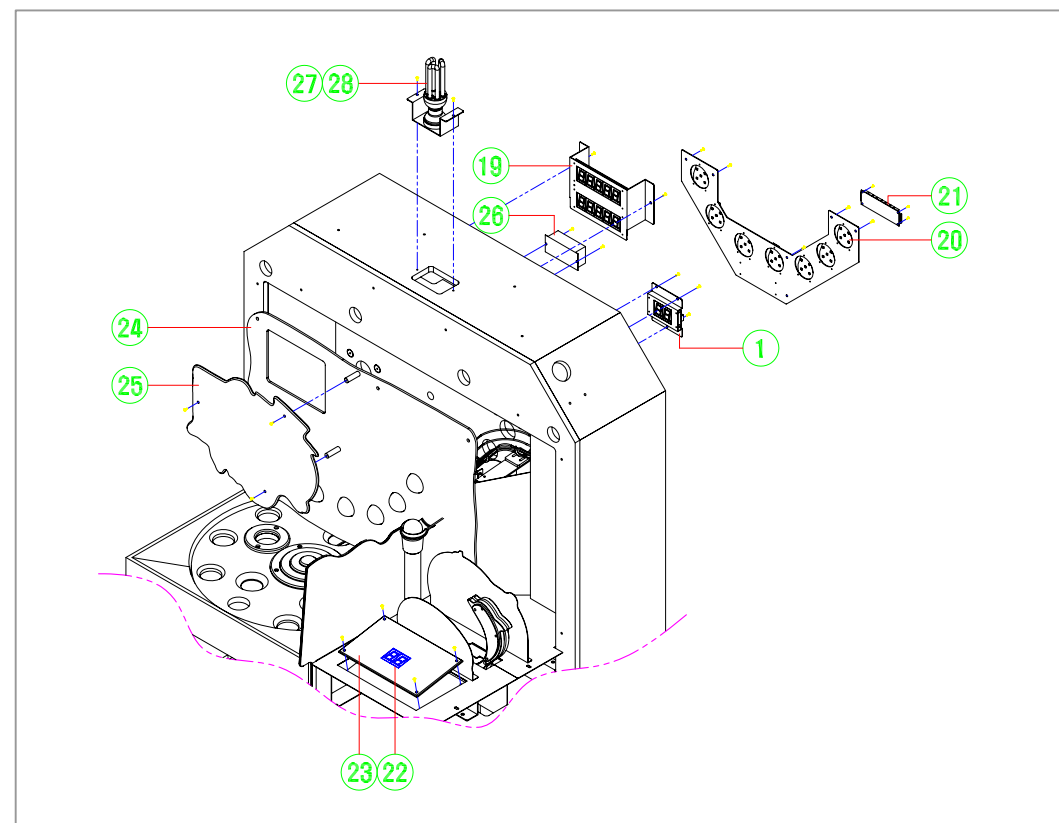

8-2. LIST

NO.	PIC	LEVEL	PART NAME	SPEC.	QTY	CODE NO.
1		1	<b>BILLBOARD CASE ASS'Y</b>			
2	○	2	BILLBOARD FRONT ACRYL	-	1	MDOS0ACR020
3	○	2	BILLBOARD REAR ACRYL		1	MDOS0ACR015
4	○	2	BILLBOARD SPEAKER MOLDING	-	2	MDOS0MOL006
5	○	2	SPEAKER LED PCB ASS'Y	-	4	ADOS0PCB008
6	○	2	SPEAKER	MID4.5"+TW1/2" 8	2	MZZZ0SPE021
7		1	<b>MAIN CABINET PART</b>			
8	○	2	FRONT COVER MOLDING	-	1	MDOS0MOL004
9	○	2	LAMP BUTTON	CWB 401-BLUE COLOR	1	MZZZ0BUT072
10	○	2	FRONT R DOOR ACRYL	-	1	MDOS0MOL003
11	○	2	KEY ASS'Y	7001	2	MDZZZ0KEY032
12		1	<b>WINDOW CABINET PART</b>			
13	○	2	WINDOW CABINET GLASS	-	2	MDOS0GLA001
14	○	2	SIDE EDGE MOLDING-R	-	1	MDOS0MOL002
15	○	2	SIDE EDGE MOLDING-L	-	1	MDOS0MOL007
16	○	2	LAMP CLAMP	-	2	MELE0LAM014
17	○	2	FLUORESCENT LAMP	FPL-36W	1	MELE0LAM002
18		1	<b>UPPER CABINET PART</b>			
19	○	2	JACKPOT FND PCB ASS'Y	-	1	ADOS0PCB004
20	○	2	SHOW TIME LED PCB ASS'Y	-	1	ADOS0PCB006
21	○	2	SHOW TIME LED CONTROL PCB ASS'Y		1	ADOS0PCB007
22	○	2	CREDIT FND PCB ASS'Y	-	1	ADOS0PCB005
23	○	2	CREDIT FND ACRYL	-	1	MDOS0ACR011
24	○	2	SHOW TIME ACRYL	-	1	MDOS0ACR008
25	○	2	SHOW TIME DECO ACRYL-B	-	1	MDOS0ACR010
26	○	2	ELECTRONIC BALLAST	110V(220V)-1동용	1	MELE0BAL010
27	○	2	AC RECEPTACLE	삼파장 소켓	1	MELE0ARE002
28	○	2	LAMP	3 WAVE(110-20W)	1	MELE0LAM005
29		1	<b>GAME PANEL PART</b>			
30	○	2	DC MOTOR	KGY-300-12V15W	1	MZZZ0MOT046
31	○	2	PHOTO INT2 PCB ASS'Y	-	2	AWIW0PCB009
32		2	MICRO SWITCH	CNR-05H-03_ZIPPY	2	MELE0MIC002
33	○	2	DC MOTOR	K6D-12V-15W	1	MZZZ0GEA004
34	○	2	GEAR HEAD	K6D-30:1	1	MELE0LAM005
35	○	2	BALL CHECK SENSOR PCB ASS'Y	-	1	ADOS0PCB003

NO.	PIC	LEVEL	PART NAME	SPEC.	QTY	CODE NO.
36	○	2	DOLPHIN SHOOTER ACRYL-A	-	1	MDOS0ACR016
37	○	2	DOLPHIN SHOOTER ACRYL-B	-	1	MDOS0ACR017
38	○	2	DOLPHIN SHOOTER ACRYL-C	-	1	MDOS0ACR018
39		2	WHEEL OUTER MOLDING	-	1	MDOS0MOL001
40	○	2	GAME PANEL PARTITION ACRYL	-	1	MDOS0ACR007
41	○	2	DC MOTOR	KGY-126-12V15W	1	MZZZ0MOT051
42	○	2	SCREW	-	12	MDOS0PLA001
43	○	2	RAMA INT1 PCB ASS'Y	-	2	ACIR0PCB011
44		1	<b>LOWER CABINET PART</b>			
45	○	2	NOISE FILTER	IP-0642-H2	1	MELE0NOI002
46	○	2	PUBLIC MAIN PCB ASS'Y	-	1	ADOS0PCB001
47	○	2	SOUND ROM PCB ASS'Y	-	1	ADOS0PCB002
48	○	2	POWER SMPS	-	2	MELE0SMP034
49	○	2	AC JOIN PCB ASS'Y	-	1	AZZZ0PCB100
50	○	2	TICKET DISPENSER	D TYPE ROHS	1	MZZZ0TID003
51	○	2	BUTTON	AMIPB-26HS-R12D	1	MMUM0BUT002
52	○	2	GUIDE RAIL	3단-300mm	2	MMUM0000004
53	○	2	COIN BOX	-	1	MDRE0PLA007
54	○	2	KEY ASS'Y	6001	1	MZZZ0KEY041
55	○	2	SETUP LCD PCB ASS'Y	-	1	AZZZ0PCB084
56	○	2	PUSH BUTTON SWITCH	DS-412R	1	MELE0PUS006
57	○	2	COUNTER	AMMC-712(OA127CL)	2	MZZZ0COU002
58	○	2	ROCKER SWITCH	T-125 4P	1	MELE0SWI004
59	○	2	VOLUME PCB ASS'Y		1	APUJ0PCB005
60	○	2	VOLUME KNOB		3	MELE0VOL007
61	○	2	ELECTRONIC BALLAST	110V(220V)-1동용	2	MELE0BAL010
62	○	2	LAMP CLAMP		4	MELE0LAM014
63	○	2	FLUORESCENT LAMP		2	MELE0LAM002
64	○	2	LOWER CORNER ACRYL		2	MDOS0ACR002
65	○	2	COIN SELECTOR	SG-968	2	MZZZ0COS012

### 8-3. PICTURE

2	3	4	5	6	8
					
9	10	11	13	14,15	16
					
17	19	20	21	22	23
					
24	25	26	27	28	30
					
31	33,34	35	36,37,38	40	41
					
42	43	45	46,47	48,49	50
					
51	52	53	54	55	56
					
57	58	59	60	61	62
					

63	64	65
